



PRACTICAL SHOOTING
OFFICIAL NATIONAL RULES

Revised September 2018

No. 5

HISTORY AND AMENDMENTS

Date issued	Edition / Version	Section / Rule	Amendment
2009	No. 3	various	Amendments as per 2008 NDC Meeting
2010	No. 4	various	Amendments as per 2009 NDC Meeting
2015	No. 4 (Reprinted with Appendix 4)	Appendix 4 added	Addition as per NDC meeting
2018 (September)	No. 5	Various	Revision approved by the SSAA National Board

Table of Contents

SECTION 1: AIMS AND OBJECTIVES.....	5
1.1 AIMS AND OBJECTIVES.....	5
SECTION 2: SSAA STANDARD RULES	5
2.1 COMPETITOR'S ELIGIBILITY	5
2.2 JUNIOR COMPETITORS.....	5
2.3 PERSONS WITH DISABILITIES	6
2.4 COMPETITOR'S RESPONSIBILITY	6
2.5 STUCK LIVE ROUND: MANDATORY RULE	6
2.6 RULE INFRINGEMENTS.....	6
2.7 DISCIPLINE CHAIRMAN'S AUTHORITY.....	6
2.8 PROTEST AND APPEALS COMMITTEE	6
2.8 SUPPLEMENTARY EVENTS	6
SECTION 3: FIREARM SPECIFICATIONS.....	6
3.1 HANDGUNS.....	6
3.2 HANDGUNS OPEN CLASS	7
3.3 HANDGUNS PRODUCTION CLASS	7
3.4 HANDGUNS STANDARD CLASS.....	8
3.5 HANDGUNS STANDARD CLASS - REVOLVER	8
3.6 HANDGUNS OPEN CLASS - REVOLVER.....	8
3.7 HANDGUNS CLASSIC PISTOL CLASS	8
3.8 HANDGUNS SMALL PISTOL CLASS.....	9
3.9 POWER FACTOR: HANDGUNS.....	9
3.10 SHOTGUNS.....	9
3.11 SHOTGUNS STANDARD CLASS.....	10
3.12 SHOTGUNS OPEN CLASS	10
3.13 POWER FACTOR: SHOTGUNS.....	11
3.14 RIFLES	11
3.15 RIFLES STANDARD CLASS	11
3.16 RIFLES OPEN CLASS.....	12
3.17 POWER FACTOR: RIFLES.....	12
SECTION 4: EQUIPMENT AND MODE OF DRESS FOR COMPETITORS	12
4.1 BELTS.....	12
4.2 HOLSTERS.....	12
4.3 ANCILLARY EQUIPMENT	13
4.4 CLOTHING	13
SECTION 5: STAFFING REQUIREMENTS AND DUTIES	14
SECTION 6: COURSES OF FIRE	15
6.1 DESIGN PRINCIPLES	15
6.2 START POSITIONS.....	15
6.3 DEFINITIONS	15
6.4 TYPES OF COURSES OF FIRE.....	16
6.5 BASIC COURSES OF FIRE.....	17
6.6 STAGE POINTS.....	17
6.7 PUBLICATION OF COURSE REQUIREMENTS.....	18

6.8	TARGETS.....	18
6.9	SCORING.....	19
6.10	SCORE SHEETS.....	19
6.11	CALCULATION OF SCORES.....	20
SECTION 7: COURSE DESIGN.....		21
7.1	GENERAL.....	21
7.2	RANGE EQUIPMENT.....	21
7.3	SAFETY IN COURSE DESIGN AND CONSTRUCTION.....	22
7.4	CHRONOGRAPH.....	22
SECTION 8: PENALTIES.....		23
8.1	SCORING PENALTIES.....	23
8.2	PROCEDURAL AND GENERAL PENALTIES.....	24
8.3	SAFETY PENALTIES.....	24
SECTION 9: RANGE PROCEDURES.....		25
9.1	READY CONDITIONS: HANDGUNS.....	25
9.2	READY CONDITIONS: RIFLES AND SHOTGUNS.....	26
9.3	RANGE COMMANDS.....	26
SECTION 10: COMPETITORS.....		27
10.1	EQUIPMENT.....	27
10.2	AMMUNITION.....	27
10.3	SCORING.....	27
10.4	COURSE OF FIRE.....	28
SECTION 11: COMPETITOR GRADES AND GRADING.....		28
11.1	GRADES.....	28
11.2	GRADING.....	28
SECTION 12: NATIONAL CHAMPIONSHIPS.....		29
APPENDIX 1: STANDARD SSAA PRACTICAL SHOOTING TARGET PST1		30
APPENDIX 2: SSAA PRACTICAL SHOOTING TARGET PST2.....		31
APPENDIX 4: RANGE EQUIPMENT.....		33
APPENDIX 5: CALIBRATION OF POPPERS.....		34
APPENDIX 6: TRIGGER PULL TEST PROCEDURE		35
APPENDIX 7: SUPPLEMENTARY EVENTS.....		36

These Rules, for the conduct of National Championships, have been compiled by the Discipline Subcommittee, with amendments by the SSAA National Discipline Chairmans' Conference and approved and ratified for printing by the SSAA Inc National Board.

SSAA PRACTICAL SHOOTING COMPETITIONS NATIONAL RULES

SUITABLE FOR BOTH CENTREFIRE AND RIMFIRE PISTOL, RIFLE AND SHOTGUN

REVISED September 2018

No. 5

SECTION 1: AIMS AND OBJECTIVES

1.1 AIMS AND OBJECTIVES

- 1.1.1 Practical shooting is intended to offer a challenging and active sport which will test the proficiency of the competitor and the reliability of their equipment.
- 1.1.2 Practical shooting is intended to stimulate new ideas, designs and techniques with regard to firearms, sights and ammunition.

SECTION 2: SSAA STANDARD RULES

The SSAA Standard Rules cover common rules, including the protest and appeals process that apply to all disciplines.

The current edition of the Standard Rules is available on the SSAA website at www.ssaa.org.au/standard-rules

These Standard Rules should be used with each discipline's current rule book and they take precedence over any rule that may be in a discipline's rule book.

The Rules covered are shown as heading and subheadings in this rule book.

2.1 COMPETITOR'S ELIGIBILITY

2.2 JUNIOR COMPETITORS

2.3 PERSONS WITH DISABILITIES

2.3.1 Authorisation

2.3.2 Substitute position

2.3.3 Awards, trophies, records, etc.

2.3.4 Protests

2.4 COMPETITOR'S RESPONSIBILITY

2.4.1 Competitors and Officials to be familiar with the Rules

2.4.2 Sportsmanship

2.4.3 Behaviour

2.4.4 Range Safety Rules

2.4.5 Safety Equipment

2.4.6 Clothing

2.5 STUCK LIVE ROUND: MANDATORY RULE

2.6 RULE INFRINGEMENTS

2.7 DISCIPLINE CHAIRMAN'S AUTHORITY

2.8 PROTEST AND APPEALS COMMITTEE

2.8 SUPPLEMENTARY EVENTS

SECTION 3: FIREARM SPECIFICATIONS

Practical shooting is intended to test the proficiency of the competitor in the use of practical firearms and equipment.

Firearm classes all compete together.

3.1 HANDGUNS

Handguns used in a match must be serviceable and safe. Range Officers will order the removal from the range of any unsafe firearm.

3.1.1 Any type of handgun may be used for practical shooting.

3.1.2 All handgun types will compete together under the same match conditions.

- 3.1.3** For each class, except Production, there will be two sections for scoring purposes – Self-loading and Revolver.
- 3.1.4** The minimum calibre for all handguns used in a match shall be .22 Long Rifle.
- 3.1.5** The minimum calibre for Open, Standard, Production and Classic Pistol class will be 9 x19 (9 mm Luger)
- 3.1.6** 9 x19 (9 mm Luger) will be scored as Minor only in Standard class and Classic Pistol class (as long as they meet 125 PF minimum).
- 3.1.7** There will be no restriction on the weight of trigger pull, except in Production class provided it functions as originally intended.
- 3.1.8** Handguns may be inspected at any time to ensure that the following devices, if appropriate, are serviceable: -
- Safety mechanism
 - Disconnecter
 - Half cock notch
 - Hammer block
- 3.1.9** Trigger shoes are not permitted.
- 3.1.10** One handgun only must be used by a competitor in all stages of a single match. If, during a match, the original handgun becomes unserviceable, with the Range Officer's approval, the competitor may continue to compete using any handgun of the same type provided the competitor does not gain an advantage over their prior handgun and the ammunition passes the chronograph test.

If either the original or replacement handgun is Minor Calibre or Small Pistol, the match will be scored as Minor Calibre or Small Pistol, as appropriate.

3.2 HANDGUNS OPEN CLASS

- 3.2.1** Any handgun that meets the general requirements set out in Section 3.1.
- 3.2.2** Any type of sights is permitted.
- 3.2.3** Extension magazines are permitted provided their overall length inclusive of any material fixed to the base plate does not exceed 170 mm.

3.3 HANDGUNS PRODUCTION CLASS

- 3.3.1** Any self-loading double action firearm with a minimum trigger pull for the first shot of 2.272 kg and a maximum barrel length of 127 mm. No internal or external modifications using non-factory parts are permitted but polishing and detailing of factory parts is permitted.
- 3.3.2** All magazines must conform to the original manufacturer's dimensions for standard magazines (unless restricted by legislation).

3.3.3 Compensators, ports and optics are not permitted.

3.3.4 Production class will be scored as Minor Calibre only (as long as they meet 125 PF Minimum).

3.4 HANDGUNS STANDARD CLASS

3.4.1 Any handgun produced by a factory in a production run of 100 units or more, or a handgun assembled from components which comply with the specifications of such a factory produced handgun.

3.4.2 Minor modifications such as beavertails, extended safeties, magazine wells, triggers, replacement barrels, etc. are allowed. No compensators, ports, or optics will be allowed.

3.4.3 Extension magazines are permitted provided their overall length inclusive of any material fixed to the base plate does not exceed 170 mm.

3.4.4 Moon clips, chamber chamfering, replacement grips, replacement sights (not optical) and general polishing and tuning of parts are permitted.

3.5 HANDGUNS STANDARD CLASS - REVOLVER

3.5.1 Any Revolver produced by a factory in a production run of 100 units or more, or a handgun assembled from components which comply with the specifications of such a factory produced handgun.

3.5.2. Minor modifications such as beavertails, extended cylinder releases, triggers, replacements barrels, moon clips, chamber chamfering, replacement grips, replacement sights (not optical) and general polishing and tuning of parts is permitted. Optical sights, ports and/or compensators are not permitted.

3.5.3 Moon clips, Chamber chamfering, replacement Grips, replacement sights (not optical) and general polishing and tuning of parts are permitted.

3.6 HANDGUNS OPEN CLASS - REVOLVER

3.6.1 Any revolver that meets the general requirements set out in section 3.1

3.6.2 Any type of sights are permitted

3.7 HANDGUNS CLASSIC PISTOL CLASS

3.7.1 Handguns must be based on and visibly resemble the profile and contours of the classic 1911-genre design, up to and including .45 ACP. This means a single-stack, one-piece metal frame, slide with stirrup cuts, and a dust cover (with or without an accessory rail)

3.7.2 Optical sights are not permitted.

3.7.3 Magazines available to a competitor during a course of fire must not contain more than 8 rounds (for major power factor) and 10 rounds (for minor power factor) at the start signal.

3.8 HANDGUNS SMALL PISTOL CLASS

3.8.1 Any pistol with a minimum calibre of .22 Long Rifle

3.9 POWER FACTOR: HANDGUNS

3.9.1 Regardless of class, handguns will be classified as one of three power categories called Major, Minor and Small Pistol.

3.9.2 9 mm x 19 will be classified as Minor category only in Standard and Classic Pistol Class (as long as they meet the 125 PF Minimum).

3.9.3 The power factor will be established by using the following formula:-

$$\text{Power factor} = \frac{\text{bullet weight (grains)} \times \text{velocity (feet per second)}}{1000}$$

3.9.4 Major shall have a minimum power factor of 160, minimum bullet weight 120 grains and a minimum bullet diameter of .354 inch.

3.9.5 Minor shall have a minimum power factor of 125.

3.9.6 Small Pistol shall have a minimum calibre of .22 Long Rifle and a minimum power factor of 35.

3.10 SHOTGUNS

All Shotguns must comply with the relevant State or Territory laws and legislation.

3.10.1 All types of actions are permitted.

3.10.2 Any type of calibre or bore is permitted.

3.10.3 Any barrel length is permitted.

3.10.4 Any type of stock is permitted.

3.10.5 All types of shotgun actions must have a fully operational safety mechanism.

3.10.6 Only one shotgun can be used by a competitor in all stages of a single match. If during the match, the original shotgun becomes unserviceable, the competitor (with the Range Officer's approval), may continue to compete in the match using any shotgun of the same type provided the competitor does not gain an advantage over their prior firearm.

3.10.7 Chest mounted ammunition carriers are not permitted.

3.10.8 All shotgun action types and calibres will compete in any match under the same match conditions.

3.10.9 There is no restriction on the weight of trigger pull provided it is safe for the type of firearm.

3.10.10 Trigger shoes may be used but must not protrude beyond the width of the trigger guard.

3.11 SHOTGUNS STANDARD CLASS

3.11.1 Standard Class will be divided into five action divisions

- Break barrel action
- Lever action
- Pump action
- Semi-automatic action
- Straight pull and other action types

3.11.2 All shotguns and equipment in Standard Class must satisfy and comply with the general shotgun criteria outlined in Section 3.10

3.11.3 Optics, compensators, porting, firearm mounted ammunition carriers or any modification to the original factory operation of the firearm mechanisms' is not permitted.

- Polishing of internal parts is permitted
- Installation of barrel heat shields is permitted
- Installation of barrel chokes is permitted
- Installation of non-factory fibre optic sights is permitted
- Slings are permitted and may be added or removed at any time throughout the match
- Tactical style chest rig slings are not permitted

3.11.4 All shotguns in Standard Class may only be loaded directly by hand. The use of speed loaders, speed tubes, round guides or firearm mounted ammunition carriers, to feed rounds into the firearm are not permitted.

3.12 SHOTGUNS OPEN CLASS

3.12.1 Open Class will be divided into five action divisions

- Break barrel action
- Lever action
- Pump action
- Semi-automatic action
- Straight pull and other action types

3.12.2 All shotguns and equipment in Open Class must satisfy and comply with the general shotgun criteria outlined in Section 3.10

3.12.3 Optics, compensators, porting, firearm mounted ammunition carriers or any modification to the original factory operation of the firearm mechanisms' is not permitted.

- Polishing of internal parts is permitted
- Installation of barrel heat shields is permitted
- Installation of barrel chokes is permitted
- Installation of non-factory fibre optic sights is permitted
- Slings are permitted and may be added or removed at any time throughout the match
- Tactical style chest rig slings are not permitted

3.12.4 All shotguns in Open Class may only be loaded directly by hand. The use of speed loaders, speed tubes, round guides or firearm mounted ammunition carriers, to feed rounds into the firearm are not permitted.

3.13 POWER FACTOR: SHOTGUNS

3.13.1 All shotguns in calibre in 20 gauge or greater are scored as Major.
All shotguns in calibre less than 20 gauge are scored as Minor.

3.13.2 All shotgun ammunition types and velocity are permitted, provided it safe to use in the firearm to be used by the competitor.

3.14 RIFLES

3.14.1 Any type of action is permitted.

3.14.2 There is no minimum or maximum calibre.

3.14.3 There is no restriction on barrel length except those required by legislative requirements.

3.14.4 Any type of stock is permitted provided it is safe and satisfies local firearms regulations.

3.14.5 There is no restriction on the weight of trigger pull provided it is safe for the type of firearm.

3.14.6 Trigger shoes may be used but must not protrude beyond the width of the trigger guard.

3.14.7 Safety mechanisms, engagement sears and disconnectors must be serviceable at all times.

3.14.8 One rifle only, must be used by a competitor in all stages of a single match. If during the match, the original rifle becomes unserviceable, with the Range Officer's approval, the competitor may continue to compete using any rifle of the same type provided the competitor does not gain an advantage over their prior firearm and the ammunition passes the chronograph test.

If either the original or replacement firearm is Minor Calibre the match will be scored as Minor Calibre.

3.15 RIFLES STANDARD CLASS

3.15.1 Standard class will be divided into two categories "Bolt Action" and "Other action types".

3.15.2 Compensators, ports and optics are not permitted.

3.15.3 Bipods and slings are not permitted.

3.15.4 Speed loaders and other loading aids are not permitted. Spare magazines are permitted.

3.16 RIFLES OPEN CLASS

3.16.1 All rifles must meet the general requirements of section 3.14.

3.16.2 Open Class will be divided into two categories “Bolt Action” and “Other action types”.

3.16.3 Any type of sight is permitted.

3.16.4 Porting and compensators are permitted.

3.16.5 Speed loaders and other loading aids are permitted.

3.16.6 Bi-Pods and Slings are permitted and may be added or removed at any time during the match.

3.17 POWER FACTOR: RIFLES

3.17.1 Rifles will be classified as Major, Minor or Small power factor.

Major Power Factor will have a minimum power factor of 340.

Minor Power Factor will have a minimum power factor of 160.

Small will be any cartridge with a minimum power factor of 35 and that does not meet the minimum power factor of 160.

The power factor is determined by:-

$$\text{Power Factor} = \frac{\text{Bullet weight (grains)} \times \text{velocity (feet per second)}}{1000}$$

SECTION 4: EQUIPMENT AND MODE OF DRESS FOR COMPETITORS

4.1 BELTS

4.1.1 The belt upon which the holster and other equipment is carried must be worn at the normal waist level.

4.1.2 The belt must be held in place by threading through the belt loops or other appropriate means (e.g. keepers or hook and loop fasteners to an under belt threaded through the belt loops).

4.1.3 Ladies may wear this belt at hip bone level. A regular belt may be worn at waist level but no equipment may be carried on the waist level belt.

4.2 HOLSTERS

4.2.1 All competitors must wear an approved holster during a handgun match. Tie down rigs, visible or otherwise, are not permitted.

- 4.2.2** The heel of the butt of the handgun when holstered must be at or above the level of the top of the belt.
- 4.2.3** The muzzle of the holstered handgun must point downward to within one metre of the competitor when standing relaxed.
- 4.2.4** The holster must cover the trigger of the handgun when holstered.
- 4.2.5** The maximum distance of any part of the inside surface of the holstered handgun from the competitor's body when standing relaxed must not exceed 50 mm.
- 4.2.6** The holster in use must retain the handgun during any of the following:-
- a standing jump
 - any activity within the course of fire.
- 4.2.7** Failure during an unloaded test of 4.2.6 causes the holster to be withdrawn until it meets the requirements.
- 4.2.8** Failure during the course of fire may lead to disqualification from the match.
- 4.2.9** If a retaining strap or locking device is fitted and required to pass the holster test, it must be used for the entire match.
- 4.2.10** Unless the competition or safety requires it, holsters may not be removed during a match.

4.3 ANCILLARY EQUIPMENT

- 4.3.1** All ammunition carriers used must be worn on the belt.
- 4.3.2** All ammunition carriers worn on the belt must retain the full magazine or speed loader during the holster test specified in 4.2.6.
- 4.3.3** After exhausting or losing the equipment worn on the belt competitors may use extra magazines, speed loaders or ammunition, from pockets, without penalty.

4.4 CLOTHING

- 4.4.1** Knee pads, elbow pads etc. may be worn to protect the knees, elbows etc. during prone or kneeling sections of a match.
See also the Standard rule 2.4.6

SECTION 5: STAFFING REQUIREMENTS AND DUTIES

5.1 To conduct a registered match the following are the recommended requirements:

- 5.1.1 MATCH DIRECTOR** - The official in charge of the entire match including design, construction, administration, squadding, scheduling, coordinating other staff and services.
- 5.1.2 SAFETY OFFICER** - The official responsible for range safety and safe course design.
- 5.1.3 CHIEF RANGE OFFICER** - The official responsible for the overall conduct of the courses of fire, briefing competitors and answering questions about the courses of fire. The Chief Range Officer is responsible for the safe and efficient operation of the match, directing the Range Officers for the stages, directing the competitors and spectators in matters concerning safety.
- 5.1.4 RANGE OFFICERS** - There should be at least one Range Officer per stage of the match or per squad if more convenient. They are responsible for conducting the competitor through the stage ensuring that the Rules are applied equally and impartially to all competitors. The Range Officer must remain close to the competitor at all times during their progress through the stage. The Range Officer's prime concern is safety.
- 5.1.5 CHIEF SCORER** - The official, who receives all score cards from the range staff, collates the scores and publishes the results.
- 5.1.6 SCORERS** - There should be at least one Scorer per stage. They will work closely with, and as instructed by, the Range Officer. They must follow the competitor and Range Officer closely and note any procedural errors made by the competitor. They will receive all score sheets from the competitors, call out and mark the scores on the score sheet, total the scores, sign the sheet, obtain the competitor's signature on the sheet and return the completed score sheets to the Chief Scorer.
- 5.1.7 PATCHERS** - There should be at least one patcher per stage. They will follow the Scorer and patch the targets after they have been scored.

SECTION 6: COURSES OF FIRE

6.1 DESIGN PRINCIPLES

- 6.1.1 Courses should be designed to equally test accuracy, speed and power.
- 6.1.2 Courses of fire are to be constantly changed to avoid any pattern becoming routine.
- 6.1.3 Courses of fire should pose a general shooting challenge which the competitor is permitted to solve within the constraints of safety and their ability.
- 6.1.4 Where a compulsory requirement such as a reload is included in the course of fire at least 1 shot must be fired after the reload to complete the stage.
- 6.1.5 All shooting challenges and time limits must be accepted provided they are safe but non-shooting scenario such as objects to be lifted or obstacles to be surmounted may be protested as too difficult or dangerous.
- 6.1.6 Targets used in Practical Shooting Competition must be approved targets for SSAA competition. See Section 6.8.

6.2 START POSITIONS

- 6.2.1 Unless otherwise stated in the stage instructions, the start position will be standing facing down range with hands naturally relaxed by sides.

6.3 DEFINITIONS

- 6.3.1 String
A number of shots to be fired and the sequence in which they are to be fired in a fixed time standard exercise stage.
- 6.3.2 Stage
An individual shooting scenario which must be timed and scored individually to earn stage points. This does not apply to standard exercises which may consist of more than one string.
- 6.3.3 Match
A shooting contest consisting of one or more stages.
- 6.3.4 Competition
A shooting contest consisting of one or more matches
- 6.3.5 Procedural Error
A failure to comply with the stated procedure as specified in the stage or match information. Each procedural error will carry a penalty twice the maximum scoring zone of the target (usually 10 points). Where the breach of

procedure gains an advantage, a procedural error will apply to each shot fired, otherwise one procedural error per occurrence.

6.3.6 Comstock Count

A shooting scenario with any number of targets that requires the competitor to place a minimum of 2 rounds on each target. The competitor may fire as many shots as are necessary to achieve this. The competitor is timed for completion of the course of fire.

6.3.7 Virginia Count

A shooting scenario with any number of targets which requires the competitor to place a minimum of 2 rounds on each target but limits the total number of rounds permitted to the minimum required to complete the course of fire. The competitor is timed for completion of the course of fire.

6.3.8 Fixed Time

A shooting scenario with any number of targets in which the competitor is told the time and maximum number of shots allowed to complete the course of fire.

6.3.9 Practical

A shooting scenario with any number of targets that must be engaged from cover. Any reloading must be done behind cover. No magazines (loaded or empty) can be left on the range behind the competitor. May be scored as Comstock, Virginia Count or Paladin.

6.3.10 Timed Fire

A shooting scenario with any number of targets that requires the shooter to place a minimum of 2 shots on each target. Any number of shots may be fired to achieve this. The stage will be scored by the time taken plus one second for each B zone hit scored and 2 seconds for each C zone hit scored

6.3.11 Strong hand / Weak hand

When strong hand and / or weak hand use is stipulated in a course of fire the competitors strong hand side will be the side the holster is attached to and the weak hand side the side the holster is not attached to.

6.3.12 Disappearing Target

Any target that when activated and has completed its movement can no longer be engaged.

6.4 TYPES OF COURSES OF FIRE

6.4.1 Published courses

Full details of the courses of fire are made available to all competitors in advance of the date or time of the match.

6.4.2 Semi-surprise courses
Competitors may view the course of fire immediately prior to the commencement of the stage, or are given limited pictorial layout without target positions, or courses selected at random from a published list of possible courses.

6.4.3 Surprise courses
Competitor starts the match or stage with little or no information other than that required for safety.

6.5 BASIC COURSES OF FIRE

6.5.1 Standard Exercises - a stage consisting of one or more strings of Fixed Time or Virginia Count scored activities.

6.5.2 Field Course or speed shoots (maximum of 6 shots) - a stage consisting of a shooting problem expressed as a course of fire which the competitor must decide how to approach and complete within the limits of the course instructions and safety requirements. Comstock Count, Virginia Count, Paladin or Timed Fire system of scoring may be used. The maximum number of rounds for a handgun stage will be 50 rounds, for a shotgun stage 25 rounds and for a rifle stage 25 rounds. For stages that involve combinations of firearm types the amounts will combine to a total, i.e. handgun and shotgun $50 + 25 = 75$ max rounds per stage.

6.5.3 Elimination Speed shoots - a speed shoot where competitors compete directly against each other in a process of elimination.

6.6 STAGE POINTS

6.6.1 The relative weight of each stage in a match will be determined by the maximum possible points available in each stage.

6.6.2 The winner of the stage will be awarded the maximum possible points for the stage. All other competitors earn stage points relative to the winner's achievement.

6.6.3 The winner of the stage will be determined by calculating the HIT FACTOR (total score minus procedural errors divided by total time). The competitor with the highest hit factor will be the winner of the stage.

6.6.4 Ties will be broken by count back of the number of "A"s, "B"s or "C"s. If a tie still remains it will be broken by a shoot off on a similar stage.

6.6.5 Other competitors' stage points will be determined by calculating their hit factor as a percentage of the winner's hit factor, then calculating their stage points as that percentage of the maximum possible points for the stage.

6.6.6 Stage points will be calculated to a minimum of 3 corrected decimal places.

6.6.7 The minimum score on any stage will be zero.

6.7 PUBLICATION OF COURSE REQUIREMENTS

6.7.1 The course instructions must set out an absolutely clear statement of the course requirements.

6.7.2 The published course of fire must set out in detail the course requirements in respect of:

- Safety considerations and Rules
- Hand positions at start
- Start position
- Range
- Mandatory reload points (if required)
- Target order (if necessary)
- Target positioning with special note of unusual target positioning, e.g. targets placed up-side down
- Use of hard or soft cover for targets and penalty targets
- Dimensions of range equipment
- Procedure for completion of the course
- All penalties applicable to the course
- Timing methods and procedure
- Stage factor
- Protest procedures

6.8 TARGETS

6.8.1 Course designers may use any of the following targets either throughout a stage or as a mixture of targets in a stage provided that no more than one size of paper target be on the same target frame.

6.8.2 SSAA or IPSC approved paper or cardboard targets.
See Appendix 1, 2 and 3 for the design.

6.8.3 Steel plate targets must fall, overturn or swing when hit. Fixed metal targets or targets that can turn edge on are not permitted.

The following steel plate targets may be used:-

- Round steel plates 20cm, 25cm and 30cm in diameter
- Steel plate the same shape as the cardboard target
- Rectangles 15cm by 25cm
- Falling plates
- Poppers
- Reaction plates

6.8.4 Steel targets must be at least 6 mm (1/4 inch) thick and be made of toughened steel plate 360 BHN (Minimum Bisalloy 80 or equivalent).

6.8.5 Frangible targets of any kind, e.g. clay targets.

6.8.6 Miscellaneous targets of any kind, e.g. bulls-eye targets.

6.8.7 Penalty targets shall be either the cardboard target with large, visible crosses drawn or painted on them or the whole target painted a distinctive colour or a steel plate or popper painted a distinctive colour.

6.9 SCORING

- 6.9.1** Cardboard targets will be scored according to the values of the zones and the power factor of the ammunition.
- 6.9.2** Where the shot touches a line it will receive the higher value.
- 6.9.3** If the target non-scoring border is either missing or too narrow or too wide the scorer shall construct a line 5 mm from the edge of the cardboard and use that line to judge the value of shots in that region of the target.
- 6.9.4** Where a penalty target is hit but the shot touches the line on the outside of the penalty target and continues on to hit the shoot target obscured by the penalty targets, the competitor will be awarded both a penalty and the score on the shoot target.
- 6.9.5** Steel Penalty Targets, not designed to fall to score a penalty, will be painted on the front surface and all edges, any mark on the paint of either the front or edge of the penalty target from a bullet strike will be scored as a penalty.
- 6.9.6** When hard cover is hit with a full diameter hole it does not incur a penalty other than a miss if appropriate. Where the shot touches the line of the hard cover a score will be recorded.
- 6.9.7** Cardboard targets are considered to be impenetrable. The hole on any target struck by a bullet which has already passed through a target will be ignored.
- 6.9.8** On turning targets any bullet hole greater than one and one half calibres in diameter will not be scored.
- 6.9.9** Disappearing targets are those that both start and finish in the disappeared position. Misses on these targets will not incur a penalty. If the target is not engaged it will incur a penalty of one procedural error.
- 6.9.10** Scoring will be judged by eye or gauged if the scorer is unsure and called out. Competitors may request gauges be used to determine close shots, double holes, etc.
- 6.9.11** Metallic targets will score either 5 points or 10 points depending on the design of the stage.
- 6.9.12** Frangible targets will score 5 points.
- 6.9.13** Other targets may be allocated a value of 5 points if the design of the stage warrants it.

6.10 SCORE SHEETS

- 6.10.1** Scores will be recorded on score sheets which, once signed by the Scorer and the competitor, may not be altered except to correct mathematical errors.

6.10.2 At National Championships electronic scoring may be used to record stage results. If electronic scoring is used competitors will be given the opportunity to view the scores on the tablet before submission and a hard copy of hit and penalty totals and time will be recorded against each competitor's name and initialled by the competitor.

6.10.3 If the score sheet is found to be incomplete at the time of entering the scores the following steps will be taken:-

Missing Name or Number	Identify missing shooter and confirm sheet with RO and/or competitor
------------------------	--

Missing Scorer or Competitor's signature	Enter scores
--	--------------

Incomplete scores, misses or times	Re-shoot
------------------------------------	----------

6.10.4 If it is not possible to identify the competitor where the Name or Number is missing from the score sheet the competitor's missing score sheets will score zero.

6.10.5 If a re-shoot is not possible the following will apply:-

Missing time	Score as zero
--------------	---------------

Missing hits or misses	Score hits as presented
------------------------	-------------------------

Extra hits	Score highest scoring hits
------------	----------------------------

6.11 CALCULATION OF SCORES

6.11.1 To calculate STAGE SCORES using a calculator or spreadsheet, follow this procedure for each stage.

- Calculate the HIT FACTOR for all competitors - score minus procedural error divided by time to a minimum of 3 corrected decimal places.
- Rank the competitors from high to low.
- Calculate the STAGE PERCENTAGE for all competitors compared to the top competitor's 100%.
- Allocate the maximum available STAGE POINTS to the top competitor.
- Use the stage percentage of each competitor to calculate their stage points for the stage.

6.11.2 To calculate MATCH SCORES from the stage scores

- Add the stage points gained for each competitor for all stages.
- Rank the competitors from high to low.
- Calculate the MATCH PERCENTAGE for each competitor as a percentage of the top competitor's score.

6.11.3 Add any additional information which is needed to identify the winners.

SECTION 7: COURSE DESIGN

7.1 GENERAL

7.1.1 Course designs may simulate various environments.

7.1.2 The maximum range at which targets should be placed is:-

- Handguns 50 metres
- Shotguns 100 metres
- Centrefire Rifles 500 metres
- Rimfire Rifles 100 metres

7.1.3 Targets shall not receive more than 12 shots before scoring and patching.

7.1.4 Targets may be concealed by either soft (may be shot through), or hard cover (deemed impenetrable). Full diameter holes through hard cover will not count for score. Hard cover may be simulated by colouring or cutting the target. Targets concealed by soft cover must be whole targets.

7.2 RANGE EQUIPMENT

7.2.1 For the recommended requirements for range equipment refer to Appendix 4.

7.2.2 Any equipment which requires the competitor to climb on or over must be strong enough to support any competitor, be securely anchored, be free of sharp or rough edges and be free of debris.

7.2.3 The maximum height of any obstacle to be climbed will be 2 metres. Any obstacle to be climbed, over 1.2 metres, must be provided with scaling aids. The competitor must have a choice of accepting a time or score penalty if they wish to move around an obstacle rather than scale it.

7.2.4 Charge lines and fault lines which define firing positions must be clearly marked on the ground. Fault lines should be defined by a solid bar at least 12.5 mm above ground level to prevent inadvertent faulting but care should be taken to prevent tripping the competitor. Fault lines may be placed at any angle deemed necessary. A fault line is deemed to be breached if the competitor fires a shot with part of their body grounded on the down range side of the fault line.

7.2.5 Cover must be of sufficient height to conceal the competitor and be of sufficient strength to be used in a braced shooting position.

7.2.6 Tunnels may be used but shall have the edges protected to prevent injury to the competitor. Competitors may fire from a tunnel but may not draw their handgun whilst in a tunnel.

7.2.7 Cooper tunnel may be used but the top material must be light enough so that it will not injure the competitor if it is dislodged.

7.2.8 The positioning of range equipment may not be changed once a match has commenced unless it is creating a safety problem and the change is ordered by the Match Director. The Match Director will then decide if all competitors will be permitted to re-shoot the stage or if the changes will only apply to

competitors who have not completed the course or if the stage must be removed from the match.

7.3 SAFETY IN COURSE DESIGN AND CONSTRUCTION

- 7.3.1** It is the responsibility of the Host Club / Branch to ensure that course designs used on their ranges are safe.
- 7.3.2** Safe angles of fire, safe target and frame construction, possible angles of ricochets, and persons in the area must always be taken into account when courses of fire are designed and constructed.
- 7.3.3** Courses of fire must not be designed in such a way as to force the competitor into unsafe actions to complete the course.
- 7.3.4** Reasonable preparation of the range surface shall be carried out by the course constructors depending on the type of course to be fired.
- 7.3.5** Any simulated or natural obstacles may be used as part of any course of fire and will apply to all competitors equally.
- 7.3.6** For any course of fire in which more than one competitor is required to fire simultaneously as a squad, it is recommended to provide a minimum of 1.5 metres free space between competitors. The squad will be organised to safely take into account competitor's equipment.
- 7.3.7** No steel target, including those used as penalties, may be fired at from a distance of less than 10 metres.

7.4 CHRONOGRAPH

- 7.4.1** A chronograph will be used to determine the power factor of a competitor's ammunition.
- 7.4.2** It is the responsibility of the Host Club / Branch or organisation to ensure that a chronograph is available on the day of the match. If no chronograph is available then no challenges to ammunition will be accepted.
- 7.4.3** The following procedure will be used:-
- Five rounds will be selected at random from a competitor's ammunition by a match official.
 - One bullet will be weighed to determine actual bullet weight, and three are fired from the competitor's gun over the chronograph. If no bullet puller and scales are available the bullet weight declared by the competitor will be used.
 - The power factor will be calculated using the actual bullet weight and the average velocity of the three rounds fired.
 - If the power factor does not reach the declared minimum, the other round will be fired over the chronograph and the power factor recalculated using the actual bullet weight and the average velocity of the three highest rounds of the four fired.

7.4.4 The power factor established by the procedure in 7.4.3 shall be used to score the match.

7.4.5 Rimfire rounds may be chronographed.

SECTION 8: PENALTIES

8.1 SCORING PENALTIES

8.1.1 Scoring penalties for the different types of shoot are as follows:

Fixed Time	Missed shot	nil
	Over time shots	5 points per shot
	Extra shots	10 points per shot
	Penalty targets	10 points per hit
	Procedural	10 points per error
	Accidental discharge	DQ
Comstock Count	Unsafe gun handling	DQ
	Missed shots	10 points per miss
	Penalty targets	10 points per hit
	Procedural	10 points per error
	Target not engaged	10 points + misses
	Accidental discharge	DQ
Virginia Count	Unsafe gun handling	DQ
	Missed shots	10 points per miss
	Extra shots	10 points per shot
	Penalty targets	10 points per hit
	Procedural	10 points per error
	Accidental discharge	DQ
Practical	Unsafe gun handling	DQ
	Procedural	As per scoring system
	Accidental discharge	DQ
Timed Fire	Unsafe gun handling	DQ
	Procedural	Plus 5 seconds
	Target not hit	Plus 10 seconds per miss
	Accidental discharge	DQ
	Unsafe gun handling	DQ

8.1.2 Disappearing targets will not be penalised for over time shots in the case of Fixed Time stages nor for missed shots in Comstock Count or Virginia Count stages.

8.1.3 Over time shots will not be penalised in Fixed Time stages unless they are more than 0.3 of a second over the specified time.

8.1.4 Extra shots fired in a Virginia Count may be penalised as either an extra shot or a procedural error but not both.

8.1.5 If a competitor does not complete the course of fire the course will be scored to the point they stop and appropriate misses and penalties will be entered for the targets not engaged.

8.2 PROCEDURAL AND GENERAL PENALTIES

8.2.1 Shots fired while in breach of a fault line will carry a procedural penalty per shot fired if an advantage is gained but 1 procedural penalty only if no advantage is gained. Breach of a fault line without firing a shot will not be penalised.

8.2.2 A Charge line is deemed to have been breached if the competitor grounds any part of their body on the out of bounds side of the charge line whether or not a shot has been fired.

8.2.3 Unless otherwise stated competitors must engage targets from specified shooting positions. Competitors may return to the shooting position they have left to correctly engage the targets if they can do so safely.

8.2.4 Targets not engaged during a stage will be penalised 1 procedural error plus misses.

8.2.5 Any roofing material from a Cooper tunnel dislodged by a competitor while traversing the tunnel will incur either 1 procedural error or a specified time penalty per unit of material dislodged.

8.2.6 Where "strong hand only" or "weak hand only" is specified in the course instructions procedural penalties shall be applied for each shot fired while using the incorrect hand.

8.2.7 Competitors moving their hands towards their handgun after the command "Standby" but before the signal to commence is given shall incur one procedural penalty, unless they return to the correct start position, in which case there is no penalty.

8.2.8 Competitors may request a penalty in lieu of attempting a part of a course requirement on the grounds of incapacity or previous injury. This penalty shall be not less than 10 seconds or 10 percent of the possible points for the stage.

8.3 SAFETY PENALTIES

8.3.1 Unsafe gun handling will bring disqualification from the match. Examples, but not a definitive list, of unsafe gun handling are:

- Allowing the muzzle to point rearwards (further than 90 degrees from the median intercept of the rear butt) at any time whilst unholstered during the course of fire. There will be a safety zone of 2 metres behind the competitor during the process of drawing or holstering.
- Dropping or causing the handgun (loaded or not) to fall at any time during the course of fire.
- Having a loaded firearm at any time other than on the firing line and under control of the Range Officer.

- Handling of firearms on the range premises where not permissible. Holstering a loaded and cocked revolver or loaded and cocked semi-automatic without the safety catch engaged.
- Moving or changing positions with the competitor's finger inside the trigger guard.
- Sweeping the muzzle of a loaded firearm over any part of the competitor's body.

8.3.2 Accidental discharge will bring disqualification from the match. If the cause of accidental discharge can be proved to be due to breakage of part of the firearm, and the competitor fulfilled all normal safety requirements adequately, the competitor will not be disqualified from the match but will be scored according to Rule 8 for the stage. An accidental discharge will cause the Range Officer to prevent any further action on the part of the competitor.

An accidental discharge is defined as:

- Any shot fired outside the butt stop
- Any shot striking the ground within 3 metres of the competitor
- Any shot fired in any direction deemed unsafe by the Host Branch / Club
- Any shot fired prior to commencement, or while loading, reloading, or taking remedial action during a malfunction
- Any shot fired during movement except when engaging targets.

8.3.3 A stage in which a stuck live round occurs will be scored according to rule 8.2.3. See also Standard Rule 2.5.

A substitute firearm may be used in subsequent stages subject to Rules 3.1.11, 3.10.8 and 3.14.8 .

SECTION 9: RANGE PROCEDURES

9.1 READY CONDITIONS: HANDGUNS

9.1.1 Unless otherwise stated in the course of fire the ready condition of handguns shall be:-

- Single action revolvers - hammer fully down on an empty chamber or in the safety notch, if fitted, over a loaded chamber or fully down on a loaded chamber if a transfer bar is fitted.
- Double action revolvers - all chambers loaded, hammer fully down.
- Single action self loader - round in chamber, loaded magazine in gun, hammer cocked and safety mechanism on safe.
- Double action self loader - round in chamber, loaded magazine in gun, hammer fully down or alternatively hammer fully cocked and external safety mechanism on safe.

- Selective action self loader - round in chamber, loaded magazine in gun and either hammer fully down or hammer fully cocked and safety mechanism on safe.

9.1.2 The ready position is the position in which the handgun is in the ready condition and in the holster or as stated in the course of fire and the competitor's hands are in the position specified in the course of fire. The competitor's stance will be erect, relaxed and natural unless otherwise stated in the course of fire.

9.2 READY CONDITIONS: RIFLES AND SHOTGUNS

9.2.1 The ready condition for rifles and shotguns shall generally be:

- Magazine filled and fitted
- Chamber loaded
- Half-cocked or safety mechanism engaged
- Bi-pods and slings in the folded or carry condition

9.2.2 The ready position for rifles and shotguns, unless otherwise stated in the course of fire, shall be:

- Firearm in the ready condition.
- Held in both hands with muzzle pointing down range, butt at waist level and visible below the elbow
- Finger outside the trigger guard
- Standing erect and facing down range

9.3 RANGE COMMANDS

9.3.1 "COMPETITOR TO THE LINE"

– The competitor moves to the start position with all appropriate equipment and awaits the next instruction from the Range Officer.

9.3.2 "LOAD AND MAKE READY"

- The competitor will face down range, fit hearing and eye protection if necessary, load the firearm and make it ready then adopt the ready position as specified in the course of fire. If the ready position involves turning up range all procedures must be complete and the hands clear of the handgun before the competitor starts to turn. When the competitor adopts the specified position the Range Officer will assume they are ready and will give the next command.

9.3.3 "ARE YOU READY?"

- If the competitor is not ready they must immediately state "NOT READY". If no answer is given within 3 seconds the Range Officer will give the next command.

9.3.4 "STAND BY"

- The competitor must remain in the ready position until the cue to commence firing is given.

9.3.5 "FIRE" COMMAND

- The cue may be verbal, visual, audible or self starting and will be given within 5 seconds of the "Standby" command being given

9.3.6 "IF YOU ARE FINISHED, UNLOAD AND SHOW CLEAR"

- When the competitor is finished or there is a cease fire, the firearm will be unloaded and held ready for inspection by the Range Officer.

9.3.6.1 Rifles and Shotguns will have the action opened, chamber and magazine empty. After your firearm is cleared, insert empty chamber indicator AND remove firearms from the range. .

9.3.6.2 Handguns

9.3.6.2.1 Semi-automatics will have the magazine removed and the slide locked or held back so the chamber can be inspected. The competitor will close the handgun, point the gun in a safe direction, fire the action and return the gun to the holster with the chamber and cylinder empty, or magazine well empty and the hammer down. After your gun is clear, hammer down and holster.

9.3.6.2.2 Revolvers will have the cylinder swung out and empty. Unloading and inspection must be carried out with the muzzle of the gun pointed down range at all times. When your gun is clear close empty cylinder and holster.

9.3.7 "RANGE IS CLEAR, FORWARD SCORE AND PATCH"

- The Range Officials may move forward to score and patch the targets and the competitor's brass may be retrieved.

SECTION 10: COMPETITORS

10.1 EQUIPMENT

10.1.1 All competitors in a registered match for Handguns must be holster qualified.

10.2 AMMUNITION

10.2.1 Any ammunition considered unsafe by the Range Officer must be removed from the range.

10.3 SCORING

10.3.1 It is the competitor's responsibility to ensure that the correct scores are entered on the score sheet / electronic scoring device.

10.3.2 After the stage has been shot competitors must not approach to within 1 metre of their targets until the score has been entered on the score sheets. Failure to observe this requirement may incur a procedural penalty.

10.3.3 Any competitor who touches one of their targets before it has been scored and may have interfered with the proper scoring of the target will have the target scored as a totally missed target with appropriate penalties.

10.3.4 A competitor may challenge the score on any target. In the first instance the Range Officer will rule on the target but their decision may be appealed to the Chief Range Officer or Match Director. Their decision may only be challenged by raising a formal protest with the Protests and Appeals Committee. The target will not be patched until the challenge is settled and it may be removed for further consideration if necessary.

10.3.5 Once the score sheet has been signed by the competitor and the Range Officer / Scorer it may not be changed except to correct mathematical errors.

10.4 COURSE OF FIRE

10.4.1 It is the competitor's responsibility to ensure they understand the Course of Fire.

10.4.2 Competitors may ask as many questions as necessary of the Range Official to ensure they understand the published details of the stage but will not be given help on solving the tactical problems of the stage.

10.4.3 Once a competitor indicates they understand the Course of Fire the Range Officer will proceed to the next command.

SECTION 11: COMPETITOR GRADES AND GRADING

11.1 GRADES

11.1.1 The following pattern will be used to allocate grades:-

85%	to	100%	MASTER
75%	to	84.9%	A
60%	to	74.9%	B
40%	to	59.9%	C
0%	to	39.9%	D

11.2 GRADING

11.2.1 Grading will be established by competing in a match.

11.2.2 Grades do not cross classes of firearm types. Competitors who want grades in more than one class, or with Revolvers as well as Self loaders, must attempt the initial grading match with the appropriate equipment.

11.2.3 Grade cards will be issued by the SSAA Practical Shooting Discipline Chairman or the SSAA National Secretariat.

11.2.4 The Host Branch / Club must ensure that the initial grading match is supervised by a suitable member of their Committee and that the score is recorded on the grading card.

11.2.5 Competitors may go up to a higher grade at any time, provided there are at least three competitors of that higher graded nominated. If they wish to go down to a lower grade they may do so after 12 months in grade and by making written application giving reasons and evidence, supported by their Branch / Club Committee, to the SSAA National Practical Shooting Discipline Chairman.

SECTION 12: NATIONAL CHAMPIONSHIPS

- 12.1** The Host Branch / Club range must be capable of running several stages of the pistol match concurrently and should have rifle and shotgun facilities available where possible.
- 12.2** A National Championship match must consist of a Major pistol match (150 rounds minimum) and can contain a rifle and shotgun match.
- 12.3** National medals will be available for the pistol, rifle and shotgun matches by class and grade. The Host Branch / Club in consultation with the National Chairman will be responsible for ordering medals as required for the event.

APPENDIX 1: STANDARD SSAA PRACTICAL SHOOTING TARGET PST1

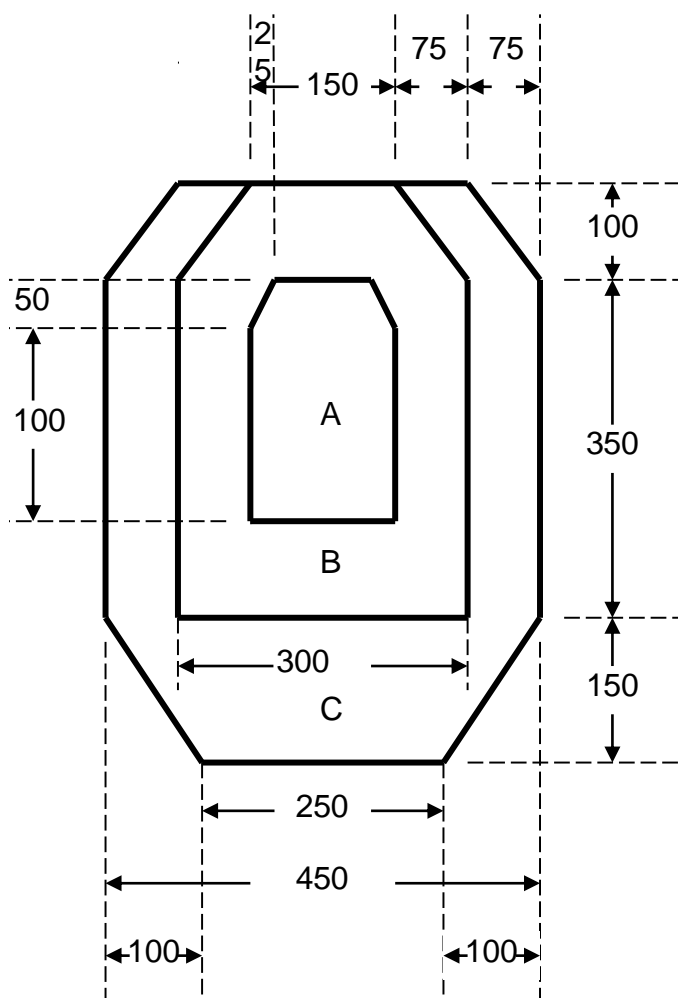

Penetrable Targets will have a 5mm non-scoring border

All figures are in millimetres (25.4mm = 1"), measurement is to the outside of the line. Tolerance shall be plus or minus 2%.

Scoring

Major

A	5
B	4
C	2

Minor

A	5
B	3
C	1

Small Pistol /Rimfire

A	3
B	2
C	0

The lines delimiting the scoring zones should not be visible from a distance of 10 metres.

APPENDIX 2: SSAA PRACTICAL SHOOTING TARGET PST2

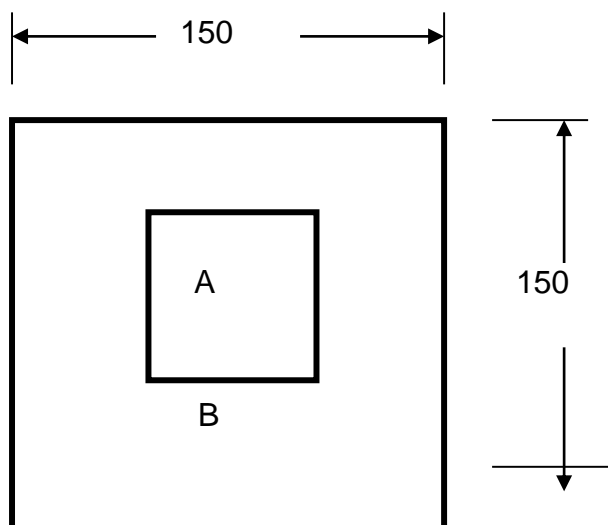

Centre square is 50mm by 50mm

Penetrable Targets will have a 5mm non-scoring border

All figures are in millimetres (25.4mm = 1"), measurement is to the outside of the line. Tolerance shall be plus or minus 2%

Scoring

Major

A	5
B	4

Minor

A	5
B	3

Small Pistol /Rimfire

A	3
B	2

The lines delimiting the scoring zones should not be visible from a distance of 10 metres.

APPENDIX 3: SSAA PRACTICAL SHOOTING TARGET PST3 (Mini)

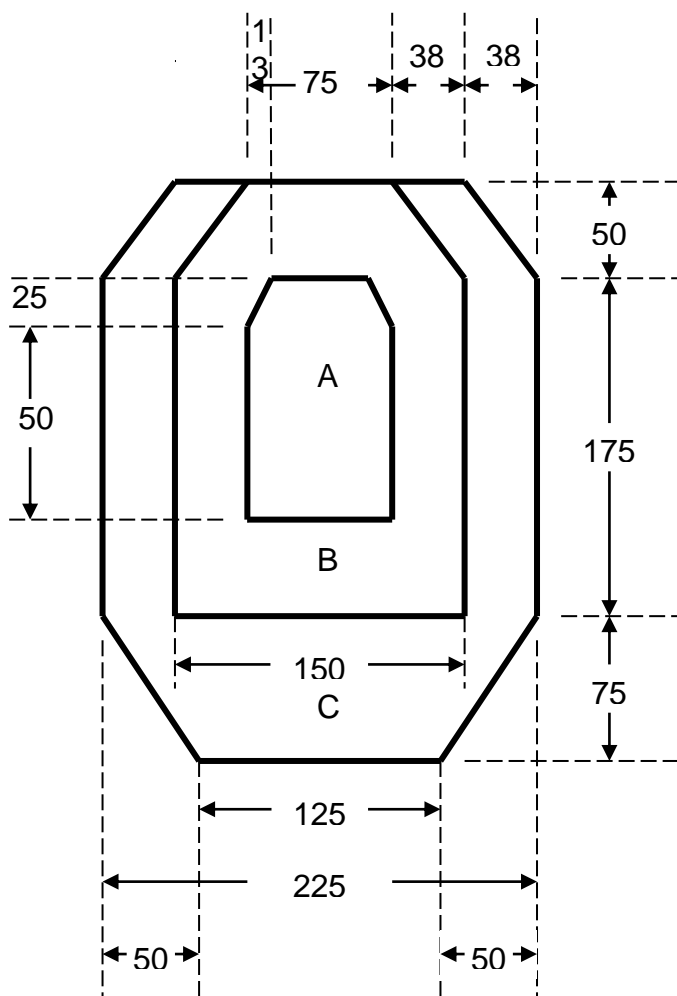

Penetrable Targets will have a 5mm non-scoring border

All figures are in millimetres (25.4mm = 1"), measurement is to the outside of the line. Tolerance shall be plus or minus 2%

Scoring

Major

A	5
B	4
C	2

Minor

A	5
B	3
C	1

Small Pistol /Rimfire

A	3
B	2
C	0

The lines delimiting the scoring zones should not be visible from a distance of 10 metres.

APPENDIX 4: RANGE EQUIPMENT

For the conduct of National Championships, this is the recommended minimum range equipment required

1. 20 standard target frames.
2. 10 wall panels 2.5 m by 2 m as follows:
 - 4 fully covered
 - 2 with 1 m wide centre opening
 - 2 with 1 m square centre window
 - 2 with 1 m square end window
3. 2 pepper poppers (Australian design)
4. 3 x 250 mm round gongs
5. 3 barricades 1800mm high by 600 mm wide with a 900 mm shooting box as per NRA Action Match specifications.

APPENDIX 5: CALIBRATION OF POPPERS

Initial Calibration

1. Poppers (steel falling targets) are to be calibrated with ammunition fired from the match calibration pistol/s which has a power factor of between 115 and 125. It is recommended that 9 x19 calibre is used.
2. Each popper must fall when hit in the calibration zone – circle at the top of the popper - when shot with a single shot from the furthest position that it may be engaged during the course of fire.

Calibration Challenges.

If a popper fails to fall when hit the competitor has 3 choices of action

1. Re shoot the target until it falls in such case there is no further action required as the popper is classed as having fallen and is scored as a hit.
2. The competitor continues the course of fire and does not challenge the calibration of the popper. No further action is required and the popper is scored as a miss.
3. The popper is left standing and the competitor challenges the calibration of the target. In this case the popper and associated props/targets are to be left untouched by any person. If a match official violates this rule the competitor will be given a reshoot. If the competitor violates this rule the target will be classed as a miss. If the popper falls for any non-interference reason (e.g. wind) then the competitor will be given a reshoot.

In the absence of interference or target mechanism failure the following procedure will be carried out by the Chief Range Officer or their nominated person (referred to as the calibration officer).

Using the match calibration pistol with the calibration ammunition the suspect popper is to be shot by the calibration officer from as near as possible the point where the competitor engaged the suspect popper.

- a) If the first shot by the calibration officer at the popper hits the popper anywhere and falls the popper, the popper will be classed as calibrated and the competitor scored as a miss for that target.
- b) If the first shot by the calibration officer at the popper hits the popper anywhere and it fails to fall the popper, then the calibration test is deemed to have failed and the competitor is awarded a reshoot after the popper has been re calibrated.
- c) If the first shot by the calibration officer fails to hit the popper, then another shot must be fired until either a) or b) above has occurred.

APPENDIX 6: TRIGGER PULL TEST PROCEDURE

Handguns will be tested as follows:

1. The unloaded handgun will be prepared as if the handgun is ready to fire a double action shot
2. The trigger weight or scale will be attached as closely as possible to the centre of the trigger face
3. The trigger of the handgun must either
 - (a) Raise and hold a 2.272 kg weight when the muzzle of the handgun is pointed vertically skywards and the handgun is gently raised;
 - (b) Register not less than 2.272 kg on a scale using the procedure specified by the trigger manufacture (or Chief Range Officer if no instructions available)
4. One of the above tests will be conducted 3 times;
5. If the hammer or striker does not fall on any 1 of the 3 attempts in 3(a) above, or if the scale registers not less than 2.27 kg (5lbs.) in 3(b) above, the handgun has passed the test;
6. If the hammer or striker falls on all three (3) attempts in 3(a) above, or if the scale registers less than 2.27 kg (5lbs.) in 3(b) above, the handgun has failed the test and the firearm will be re classified as appropriate.

APPENDIX 7: SUPPLEMENTARY EVENTS

Below is a list of Practical Shooting Supplementary events used by some States and Branches.

A.7.1 RIMFIRE SPECTRUM RIFLE

- a. 28 rounds per match
- b. rifle specifications: as per 3.8, .22 long rifle cartridge only.
- c. supported positions: supports as supplied by host branch, i.e. hay bales, logs, sandbags, etc.
- d. Competitors unable to adopt a mandated position may use the next most difficult position, e.g. Prone-sitting, sitting-kneeling, kneeling-offhand.

A.7.1.1 Course of fire

25 metres / yards Official Rimfire Target (Target A)

RAPID FIRE offhand

4 rounds in 30 sec x 2 = TOTAL 8 ROUNDS

Possible Score 80.8

60 metres / yards Steel target (i.e. RF Silhouette Chicken)

SUPPORTED – 8 rounds in 2mins 30 seconds

2 rounds standing, 2 rounds kneeling, 2 rounds sitting, 2 rounds prone

Can be shot in any order

2 min 30 sec = Total 8 rounds x 10 points per hit

Supports as supplied by host branch

Possible Score 80.0

77 metres / yards Steel target (i.e. RF Silhouette Turkey)

KNEELING or Offhand – 4 rounds in 6 minutes

Total 4 rounds x 10 points per hit

Possible Score 40.0

100 metres / yards Steel target (i.e. RF Silhouette Turkey)

PRONE or using supports as supplied by host branch

8 rounds in 2 minutes 30 seconds

2 min 30 sec = Total 8 rounds x 10 points per hit

Possible Score 80.0

TOTAL POSSIBLE SCORE 280.8

A.7.2 CENTREFIRE SPECTRUM RIFLE

- a.** 28 rounds per match
- b.** rifle specifications: as per 3.8, competition may be divided into Major and Minor power factor classes
- c.** supported positions: supports as supplied by host branch, i.e. hay bales, logs, sandbags, etc.
- d.** Competitors unable to adopt a mandated position may use the next most difficult position, e.g. Prone-sitting, sitting-kneeling, kneeling-offhand.

A.7.2.1 Course of fire

50 metres / yards Official Centrefire Target 100m/yds (Target B)

RAPID FIRE offhand

4 rounds in 30 sec x 2 = TOTAL 8 ROUNDS

Possible Score 80.8

200 metres / yards Steel target (i.e. CF Silhouette Chicken)

SUPPORTED – 8 rounds in 2mins 30 seconds

2 rounds standing, 2 rounds kneeling, 2 rounds sitting, 2 rounds prone

2 min 30 sec = Total 8 rounds x 10 points per hit

Supports as supplied by host club

Possible Score 80.0

300 metres / yards Steel target (i.e. CF Silhouette Pig)

KNEELING or Offhand – 4 rounds in 6 minutes

Total 4 rounds x 10 points per hit

Possible Score 40.0

Dual range stage - 4 rounds each range (8 rounds in 2 minutes 30 seconds)

PRONE or using supports as supplied by host branch

385 metres / yards Steel target (i.e. CF Silhouette Turkey)

500 metres / yards Steel target (i.e. CF Silhouette Ram)

2 min 30 sec = Total 8 rounds x 10 points per hit

Possible Score 80.0

TOTAL POSSIBLE SCORE 280.8